

2015-152 Upconverter, 70 MHz IF to 14.8 - 15.2 GHz

The Model 2015-152 Upconverter converts 70 ± 18 MHz to 14.8 to 15.2 GHz in 125 kHz steps with low group delay and flat frequency response. Synthesized local oscillators (LO) provide very low phase noise, ± 0.01 ppm stability frequency selection. Push button switches select the RF frequency, gain, and other parameters. Front panel LEDs provide indication of PLL alarm (red), remote operation (yellow) or the TX carrier is Muted (red). Variable attenuators for the IF input and RF output provide a gain range of 0 to +20 dB as adjusted by the front panel push-button switches. Remote operation allows selection of frequency and gain. Parameter selection and frequency and gain settings appear on the LCD display. Connectors are BNC (female) for IF, external reference input and 10MHz reference output, and SMA (female) for the RF output. The unit is powered by a 100-240 $\pm 10\%$ VAC power supply, and housed in a 1.75" x 19" x 16" 1RU chassis.

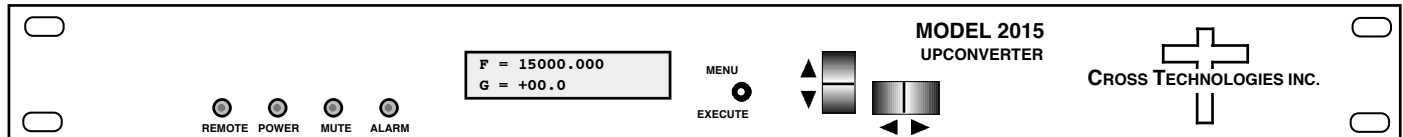

Front Panel

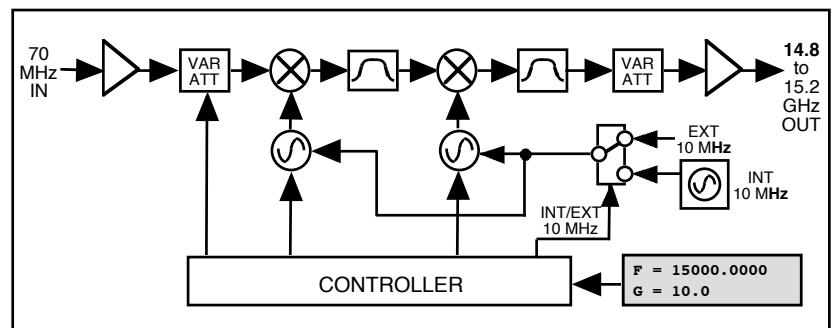

2015-152 Block Diagram

EQUIPMENT SPECIFICATIONS*

Input Characteristics

Impedance/Return Loss 75 Ω / 18 dB
 Frequency 70 \pm 18 MHz
 Input Level -30 to -10 dBm

Output Characteristics

Impedance/Return Loss 50 Ω /15 dB
 Frequency (See Models) 14.8 to 15.2 GHz
 Output level -30 to -10 dBm
 Output 1 dB compression **+0 dBm**

Channel Characteristics

Gain range (adjustable) 0 to +20 dB, **0.5 \pm 0.5 dB steps (manually adjustable)**
 Spurious Response <-50 dBC
 Frequency Response ± 1.5 dB, 14.8-15.2 GHz ; ± 0.5 dB, 36 MHz BW
 Group Delay, maximum **0.015 ns/MHz²**, parabolic, **0.035 ns/MHz**, linear, 1 ns ripple
 Frequency Sense Non-inverting

Synthesizer Characteristics

Frequency Accuracy ± 0.01 ppm internal reference; external reference input
 Frequency Step 125 kHz minimum
 10 MHz In/Out Level 3 dBm, ± 3 dB

Phase Noise @ Freq	100Hz	1kHz	10kHz	100kHz	1MHz
dBC/Hz	-70	-70	-80	-95	-105

Controls, Indicators

Freq/Gain Selection Direct readout LCD; pushbutton switches or remote selection
 Pwr; Alm; Remote; Mute Green LED; Red LED; Yellow LED; Yellow LED
 Remote RS232C, 9600 baud (**options; RS485, Q; Ethernet**)

Other

RF Connector SMA (female)
 IF Connector BNC (female), 75 Ω
 10 MHz Connectors BNC (female) **75 Ω , works with 50 or 75 ohms**
 Alarm/Remote Connector DB9 - NO or NC contact closure on Alarm
 Size 19 inch, 1RU standard chassis 1.75" high X 16.0" deep
 Power 100-240 $\pm 10\%$ VAC, 47-63 Hz, 45 watts maximum

Available Options

Z - Attenuator 0.1 dB on Upconverter

Remote M&C Interfaces:

Q - RS485/422
 W8 - Ethernet; w/Web Browser (WB)
 W18 - Ethernet; w/WB & SNMP
 W28 - Ethernet; w/TCP/IP, Telnet

Connectors/Impedance

M - 50 Ω N-type (RF), 50 Ω BNC (IF)
 N - 50 Ω N-type (RF), 75 Ω BNC (IF)
 S - 50 Ω SMA (RF), 50 Ω BNC (IF)
 SS - 50 Ω SMA (RF), 50 Ω SMA (IF)

Contact Cross for other options

*10°C to 40°C; Specifications subject to change without notice.