

2584-31 Combiner, 250 - 2150 MHz

The 2584-31 Combiner has inputs for three 500 MHz bands, Ka A (1650-2150 MHz), Ku (950-1450 MHz), and Ka B (250-750 MHz) which are then combined into a composite 250-2150 MHz output. Attenuators on the inputs allow ± 6 dB gain equalization of each band. Each band has a 0 dB gain (± 2 dB) monitor of the input (**with input equalization gain set to 0 dB**). These monitors can be used to drive external block upconverters. The gain to the composite output can be adjusted from 0 to -39 dB in 1 dB steps (**with input equalization gain set to 0 dB**). With a per carrier input of -15 dBm, the output can be adjusted over a -15 to -54 dBm per carrier level range. A -20 dB monitor of the maximum composite output (fixed level, does not vary with overall gain setting) is on the front panel. A rear panel SMA connector allows for the insertion of an external carrier within the 250-2150 MHz frequency range. The gain of this **inserted** signal is 0 dB when the overall gain is set for 0 dB. Front panel multi-function switches adjust the input **equalization gains** and overall gain. Front panel LEDs indicate DC power (green), alarm (red), and remote operation (yellow). Remote operation allows setting the overall gain. Input **equalization gain** during setup and overall gain settings during operation appear on the LCD display. **Connectors are SMA except the RF monitor which is 50 ohm BNC, and the Ka A, Ku, Ka B Monitors and the Composite output which are Type F.** Powered by a 100-240 $\pm 10\%$ VAC, 47-63 Hz power supply, it is housed in a 1 RU by 16" deep rack mount chassis.

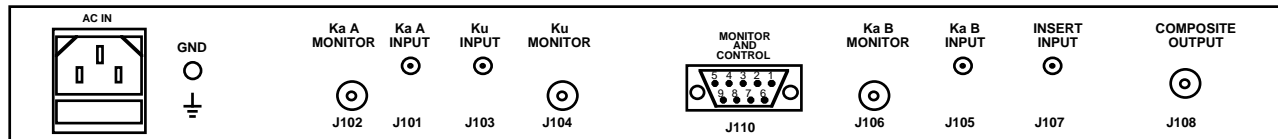
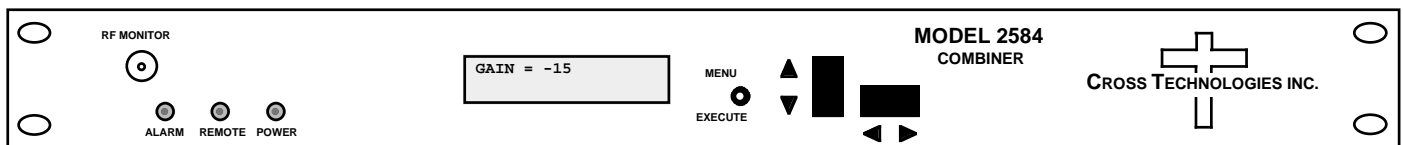

2584-31 Front and Rear Panels

EQUIPMENT SPECIFICATIONS*

Input Characteristics (IF)

Impedance/Return Loss	50Ω/12 dB
Input Level	-15 to -25 dBm per carrier
Frequency, Ka A	1650-2150 MHz
Frequency, Ku	950-1450 MHz
Frequency, Ka B	250-750 MHz
Frequency, Insertion	250-2150 MHz (Ka A, Ku, Ka B bands)

Output Characteristics (RF)

Impedance/Return Loss	75Ω/12 dB
Frequency	250-2150 MHz
Output level/carrier	-15 to -25 dBm, 0 dB gain
Output 1 dB compression	+10 dBm, 0 dB gain

Ka A, Ku, Ka B Mon Out 0 \pm 2 dB gain of the input at 0 dB input **equalization gain** setting; **Type F, 75 Ω /12 dB return loss**
Comp. Output Monitor -20 dB of the output at the 0 dB gain setting, fixed level

Channel Characteristics

Input Equalization gain	-6 to +6 dB, 1 dB steps for each band (Ka A, Ku, Ka B)
Intermodulation	< -45 dBC for two carriers each at -15 dBm out (provides Carrier Intermods < -30 dBC, 39 ON, 1 OFF)
Frequency Response	± 1.5 dB, 500 MHz BW; ± 2.5 dB, 250-2150 MHz
Gain Range	0 to -39 dB in 1 dB (± 1 dB accuracy) steps (input equalization gain is set to 0 dB)

Controls, Indicators

Pwr; Alarm; Rem	Green LED; Red LED; Yellow LED
Remote	RS232C / RS485 , 9600 baud
Gain Selection	direct readout LCD; front panel multi-function switches or remote selection

Other

RF Connectors	Ka A, Ku, Ka B In, Insert port - SMA Composite Output, Ka A, Ku, Ka B Monitors - 75 Ω Type F; RF Output Monitor - 50 ohm BNC (female)
Alarm/Remote Conn.	DB9 - NO or NC contact closure on Alarm; RS232C / RS485, 9600 Baud
Size; Power	19 inch, 1RU standard chassis 1.75" high X 16.0" deep; 100-240 $\pm 10\%$ VAC, 47-63 Hz, 30 watts max

*10°C to 40°C; Specifications subject to change without notice

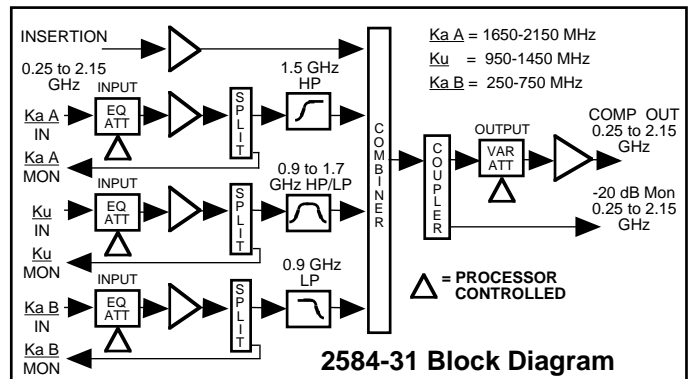

Available Options

W8- Ethernet M&C Remote Interface