

# Instruction Manual

# Model 2016-37 Downconverter

April 2020, Rev. B

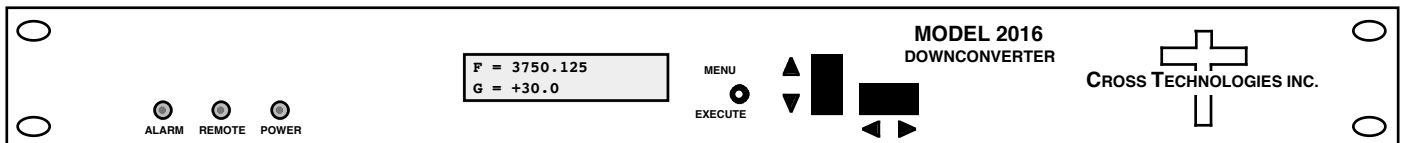

Data, drawings, and other material contained herein are proprietary to Cross Technologies, Inc., but may be reproduced or duplicated without the prior permission of Cross Technologies, Inc. for purposes of operating the equipment.

When ordering parts from Cross Technologies, Inc., be sure to include the equipment model number, equipment serial number, and a description of the part.



6170 Shiloh Road  
Alpharetta, Georgia 30005

(770) 886-8005  
FAX (770) 886-7964  
Toll Free 888-900-5588

WEB [www.crosstechnologies.com](http://www.crosstechnologies.com)  
E-MAIL [info@crosstechnologies.com](mailto:info@crosstechnologies.com)

**INSTRUCTION MANUAL**  
**MODEL 2016-37 Downconverter**

<b><u>TABLE OF CONTENTS</u></b>	<b><u>PAGE</u></b>
<b>Warranty</b>	<b>2</b>
<b>1.0 General</b>	<b>3</b>
1.1 Equipment Description	<b>3</b>
1.2 Technical Characteristics	<b>4</b>
1.3 Monitor & Control Interface	<b>5</b>
1.4 Environmental Use Information	<b>7</b>
<b>2.0 Installation</b>	<b>8</b>
2.1 Mechanical	<b>8</b>
2.2 Rear Panel Inputs & Outputs	<b>9</b>
2.3 Front Panel Controls & Indicators	<b>9</b>
2.4 Operation	<b>10</b>
2.5 Menu Settings	<b>11</b>

**WARRANTY** - The following warranty applies to all Cross Technologies, Inc. products.

All Cross Technologies, Inc. products are warranted against defective materials and workmanship for a period of one year after shipment to customer. Cross Technologies, Inc.'s obligation under this warranty is limited to repairing or, at Cross Technologies, Inc.'s option, replacing parts, subassemblies, or entire assemblies. Cross Technologies, Inc. shall not be liable for any special, indirect, or consequential damages. This warranty does not cover parts or equipment which have been subject to misuse, negligence, or accident by the customer during use. All shipping costs for warranty repairs will be prepaid by the customer. There are not other warranties, express or implied, except as stated herein.



6170 Shiloh Road  
Alpharetta, Georgia 30005

(770) 886-8005  
FAX (770) 886-7964  
Toll Free 888-900-5588

WEB [www.crosstechnologies.com](http://www.crosstechnologies.com)  
E-MAIL [info@crosstechnologies.com](mailto:info@crosstechnologies.com)

# MODEL 2016-37 Downconverter

## 1.0 General

### 1.1 Equipment Description

The 2016-37 Downconverter converts 3.625 to 4.2 GHz to  $70 \pm 18$  MHz in 125 kHz steps (1 kHz steps, option X1005) with low group delay and flat frequency response. Synthesized local oscillators (LO) provide frequency selection with  $\pm 0.01$  ppm stability. Push button switches select the RF frequency, gain, and other parameters. Front panel LEDs provide indication of DC power (green), PLL alarm (red), and remote operation (yellow). Gain is adjustable manually over a +30 to +50 dB range by the front panel push-button switches. Remote M&C allows selection of the 10 MHz reference, frequency and gain. Parameter selection and frequency and gain settings appear on the LCD display. Connectors are BNC (female) for IF output and the 10MHz reference input and output, and Type N (female) for the RF input (other connector configurations available). A 10 MHz output connector contains either the internal or external 10 MHz reference signal. The unit is powered by a 100-240  $\pm 10\%$  VAC power supply, and housed in a 1 3/4" X 19" X 16" rack mount chassis.

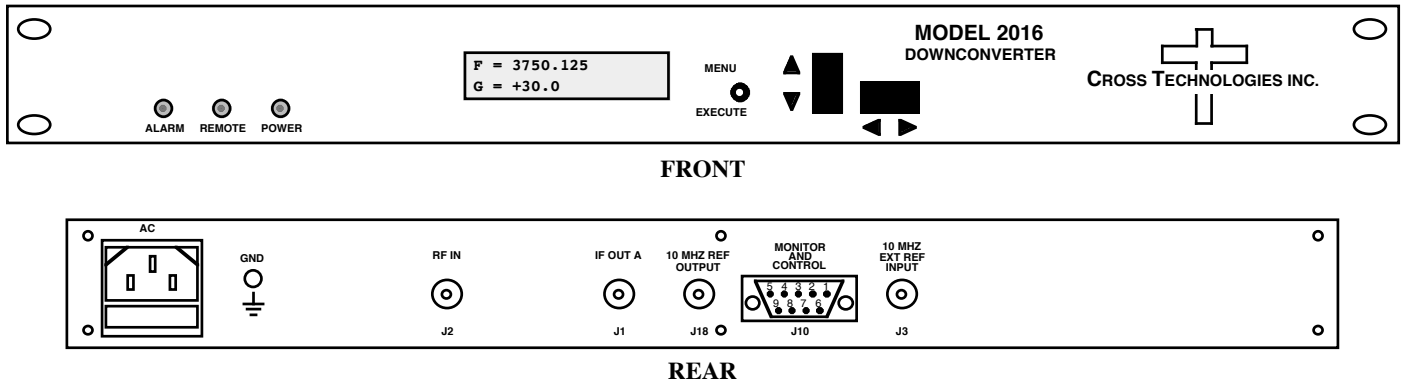

**FIGURE 1.1 Model 2016-37 Front and Rear Panels**

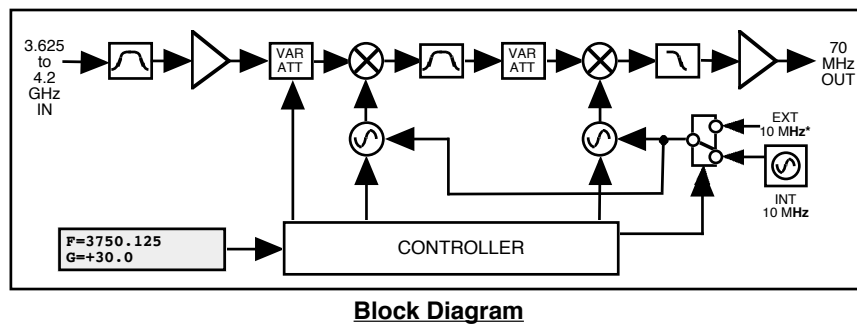

**FIGURE 1.2 Model 2016-37 Downconverter Block Diagram**

## 1.2 Technical Characteristics

**TABLE 1.0 2016-37 Downconverter Specifications\***

### **Input Characteristics (RF)**

Impedance/Return Loss	50Ω /14 dB
Frequency	3.625 to 4.2 GHz
Noise Figure, Max.	15 dB (max. gain)
Level	-70 to -30 dBm

### **Output Characteristics (IF)**

Impedance/Return Loss	75Ω/18 dB
Frequency	70 ± 18 MHz
Level	-20 to 0 dBm
1dB compression	+10 dBm

### **Channel Characteristics**

Maximum Gain Range	+50 to ±2 dB in 1db steps
Image Rejection	> 50 dB, min
Spurious Response	<-50 dBC, Maximum
Frequency Response	±1.5 dB, 3.625-4.2 GHz ; ± 0.6 dB, 36 MHz BW
Group Delay, max	0.015 ns/MHz <sup>2</sup> parabolic; 0.05 ns/MHz linear; 1 ns ripple
Frequency Sense	Non-inverting

### **Synthesizer Characteristics**

Frequency Accuracy	±0.01 ppm internal reference or external reference input
Frequency Step	125 kHz minimum; (1 kHz steps, option X1005)
10 MHz In/Out Level	3 dBm ± 3 dB

Phase Noise @ Freq	100 Hz	1kHz	10kHz	100kHz	1MHz
dBC/Hz	-70	-75	-80	-95	-110

### **Controls, Indicators**

Freq/Gain Selection	Direct readout LCD; pushbutton switches or remote selection
Power; Alarm; Remote	Green LED; Red LED; Yellow LED
Remote	RS232C, 9600 baud, RS485/422 or Ethernet Optional

### **Other**

RF Connector	Type N (female)
IF Connector	BNC (female)
10 MHz Connectors	BNC (female), 75Ω, works with 50 or 75 ohms
Alarm/Remote Connector	DB9 - NO or NC contact closure on Alarm
Size	19 inch, 1RU standard chassis 1.75”high X 16.0” deep
Power	100-240 ±10% VAC, 47-63 Hz, 45 watts max

(Continued on page 5...)

### Available Options

W7 -	RF/IF Monitor Ports (Front)
W31-	Extended Temperature 0C to +50C
X1005-	1 kHz Frequency step

### **Remote M&C Interfaces:**

Q -	RS485/422
W8-	Ethernet; with Web Browser
W18-	Ethernet; with Web Browser & SNMP
W28	Ethernet; with TCP/IP, Telnet®

### **Connectors/Impedance:**

STD -	50Ω Type N (RF), 75Ω BNC (IF)
M-	50Ω Type N (RF), 50Ω BNC (IF)
S-	50Ω SMA (RF), 50Ω BNC (IF)
S7-	50Ω SMA (RF), 75Ω BNC (IF)

Contact Cross Technologies for other options

---

\*+10°C to +40°C; Specifications subject to change without notice.

### 1.3 Monitor and Control Interface

#### A) Remote Serial Interface

**Protocol:** RS-232C, 9600 baud rate, no parity, 8 data bits, 1 start bit, and 1 stop bit.  
(RS-232C, RS-422, or **RS-485 - option -Q**)

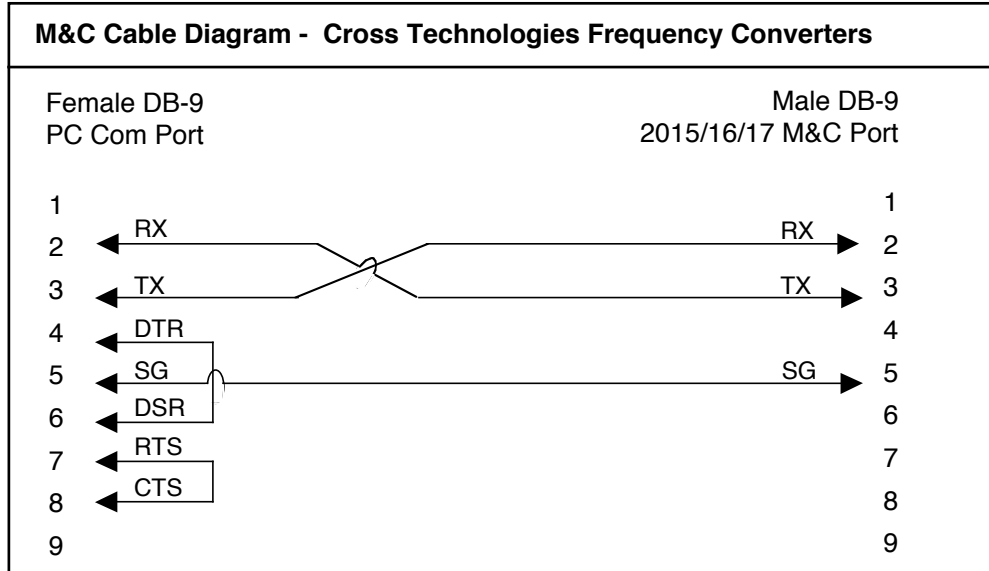

**Connector:** Rear panel, DB-9 female

J10 Pinouts (RS485/RS422)	
Pin	Function
1	Rx-
2	Rx+ (RS-232C)
3	Tx+ (RS-232C)
4	Tx-
5	GND
6	Alarm Relay: Common
7	Alarm Relay: Normally Open
8	Not Used
9	Alarm Relay: Normally Closed

## B) Status Requests

Table 1.1 lists the status requests for the 2016-37 and briefly describes them.

\* PLEASE NOTE: The two character {aa}(00-31) prefix, in the table below, should be used ONLY when RS-485, (OPTION-Q), is selected.

TABLE 1.1 2016-37 Status Requests		
Command	Syntax*	Description
Command Status	{aaS1}	Returns {S1bbbbbbcccA} where:
		• bbbbbbb = Rx frequency (in kHz)
		• cc = Rx gain
		• A = summary alarm; 1 = alarmed, 0 = normal
10MHz Ref Status	{aaS2}	Returns {S2E} where:
		• E = 1 - external 10 MHz switched in

**C) Commands** - Table 1.1 lists the commands for the 2016-37 and briefly describes them. After a command is sent the 2016-37 sends a return “>” indicating the command has been received and executed.

**General Command Format** - The general command format is {aaCND...}, where:

- { = start byte
- aa = address (**RS-485 only - option -Q**)
- C = 1 character, either C (command) or S (status)
- N = 1 character command or status request
- D = 1 character or more of data (depends on command)
- } = stop byte

\* PLEASE NOTE: The two character {aa}(00-31) prefix, in the table below, should be used ONLY when RS-485, (OPTION-Q), is selected.

Table 1.2 2016-37 Commands		
Command	Syntax*	Description
Set Receiver Frequency	{aaC2xxxxxxx}	where: <ul style="list-style-type: none"> <li>• xxxxxxx = 7 characters</li> <li>• Range: 3625000 to 4200000 kHz, in 125kHz steps</li> </ul>
Set Receiver Gain	{aaC4xx}	where: <ul style="list-style-type: none"> <li>• xx = 2 characters</li> <li>• Range: 30 to 50 (+30 dB to +50 dB, in 1.0 dB steps)</li> </ul>
Enable External 10MHz IN	{aaCEx}	where x =: <ul style="list-style-type: none"> <li>• 0 to disable External 10MHz ref signal</li> <li>• 1 to enable External 10MHz ref signal</li> </ul>
Enable Remote	#	Just # sign
Disable Remote	{aaCRO}	{CR and zero}

## 1.4 Environmental Use Information

- A. **Rack-Mounting** - To mount this equipment in a rack, please refer to the installation instructions located in the user manual furnished by the manufacturer of your equipment rack.
- B. **Mechanical loading** - Mounting of equipment in a rack should be such that a hazardous condition does not exist due to uneven weight distribution.
- C. **Elevated operating ambient temperature** - If installed in a closed or multi-unit rack assembly, the operating ambient temperature of the rack may be greater than room ambient temperature. Therefore, consideration should be given to Tmra.
- D. **Reduced air flow** - Installation of the equipment in a rack should be such that the amount of air flow required for safe operation of the equipment is not compromised. Additional space between unit may be required.
- E. **Circuit Overloading** - Consideration should be given to the connection of the equipment to the supply circuit and the effect that overloading of circuits could have on over current protection and supply wiring. Appropriate consideration of equipment name plate rating should be used, when addressing this concern.
- F. **Reliable Earthing** - Reliable earthing of rack-mounted equipment should be maintained. Particular attention should be given to supply connections other than direct connection to the Branch (use of power strips).
- G. **Top Cover** - There are no serviceable parts inside the product so, the Top Cover should not be removed. If the Top Cover is removed the ground strap and associated screw **MUST BE REINSTALLED** prior to Top Cover screw replacement. **FAILURE TO DO** this may cause **INGRESS** and/or **EGRESS** emission problems.

## 2.0 Installation

### 2.1 Mechanical

The 2016-37 consists of one RF/Controller PCB housed in a 1 RU (1 3/4 inch high) by 16 inch deep chassis. A switching,  $\pm 12$ , +24, +5 VDC power supply provides power for the assemblies. The 2016-37 can be secured to a rack using the 4 holes on the front panel. Figure 2.1 shows how the 2016-37 is assembled.

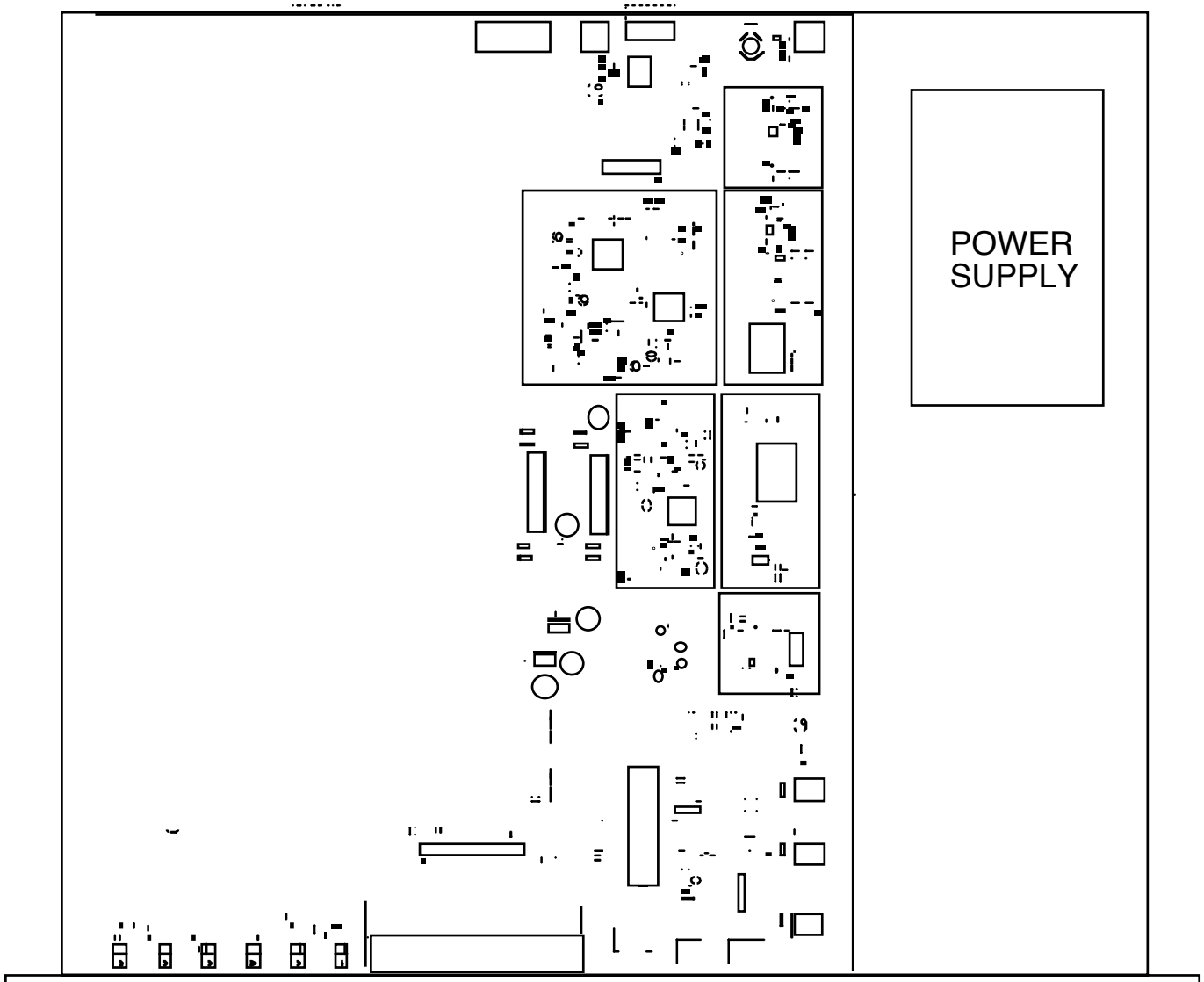

**FIGURE 2.1 2016-37 Mechanical Assembly**

## 2.2 Rear Panel Input/Output Signals

Figure 2.2 shows the input and output connectors on the rear panel.

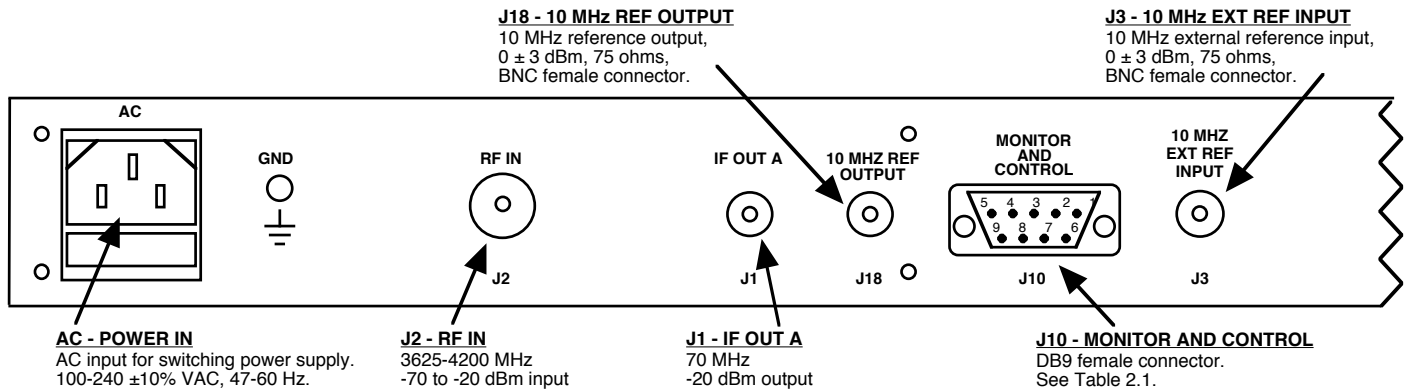

**FIGURE 2.2 2016-37 Rear Panel I/Os**

**TABLE 2.1 J10 Pinouts (RS-232C\*)**

Pin	Function
1	Not Used
2	Rx+ (RS-232C)
3	Tx+ (RS-232C)
4	Not Used
5	GND
6	Alarm Relay: Common
7	Alarm Relay: Normally Closed
8	Not Used
9	Alarm Relay: Normally Open

**TABLE 2.2 IF/RF Connector Options**

Option	IF	RF
STD	BNC, 75 $\Omega$	Type N, 50 $\Omega$
M	BNC, 50 $\Omega$	Type N, 50 $\Omega$
S	BNC, 50 $\Omega$	SMA, 50 $\Omega$
S7	BNC, 75 $\Omega$	SMA, 50 $\Omega$

### \*Remote Serial Interface

Interface: DB-9 Female

Protocol: RS-232C, 9600 baud rate, no parity, 8 data bits, 1 start bit, 1 stop bit

## 2.3 Front Panel Controls and Indicators

Figure 2.3 shows the front panel controls and indicators.

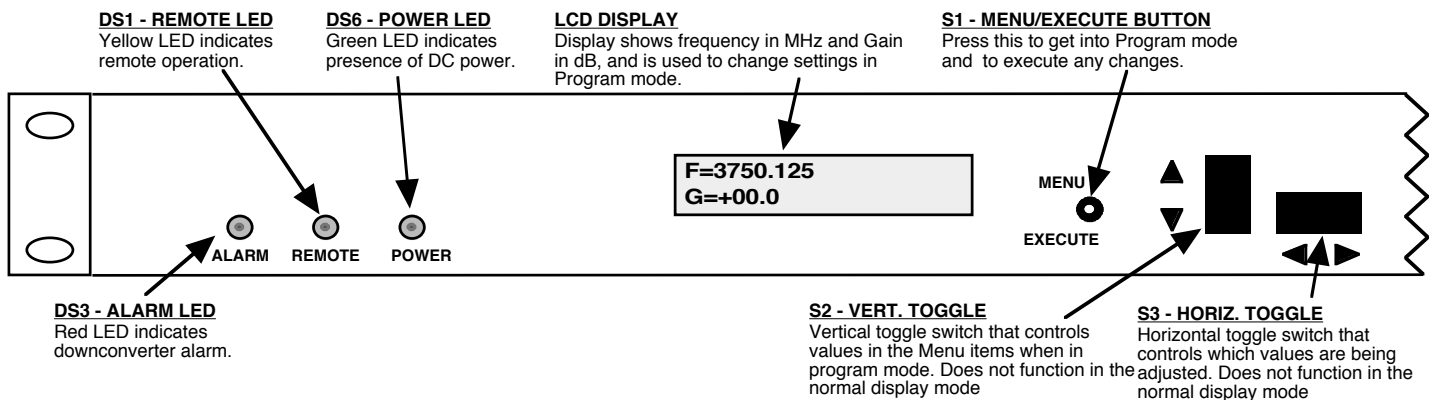
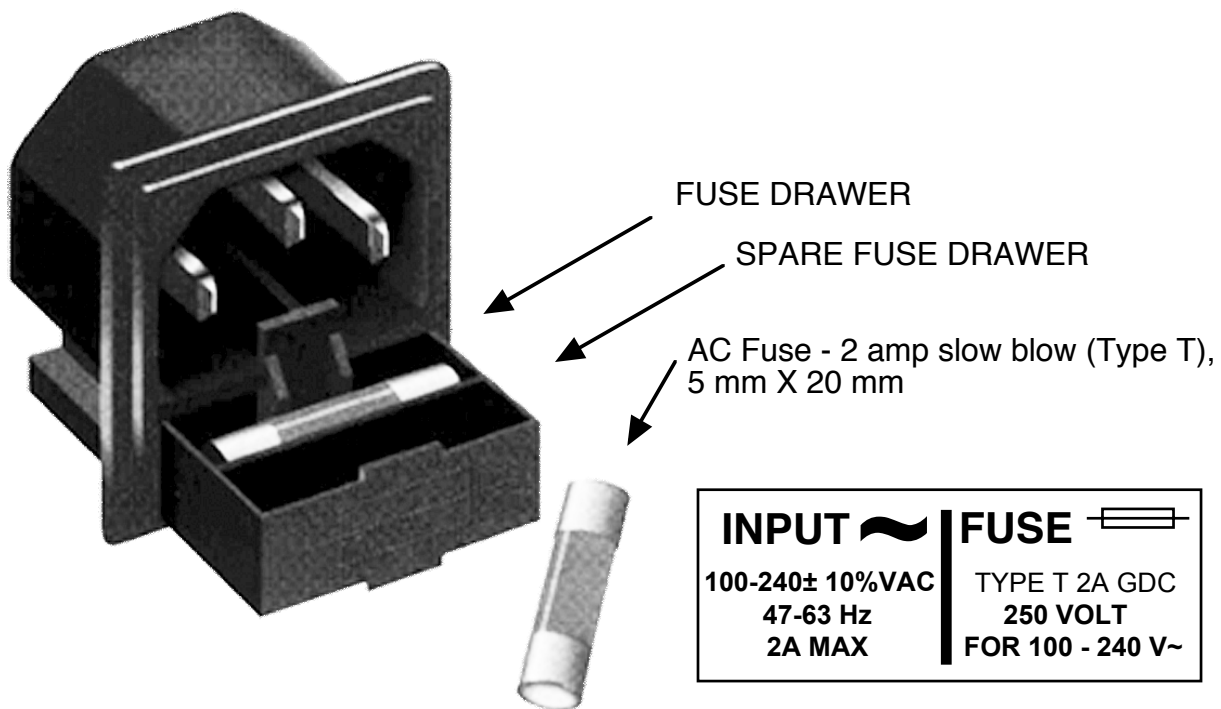

**FIGURE 2.3 2016-37 Front Panel Controls and Indicators**

## 2.4 Operation

### 2.4.1 Installing and Operating the 2016-37 Downconverter

1. Connect a -70 dBm to -30 dBm signal to RF IN, J2 (Figure 2.2).
2. Connect the IF OUT, J1, to the external equipment.
3. Connect 100-240  $\pm$ 10% VAC, 47-63 Hz to AC on the back panel.
4. Set the input frequency (See Section 2.5 Menu Settings).
5. Set the gain for +30 to +50 dB (See Section 2.5 Menu Settings).
6. Be sure DS6 (green, DC Power) is on and DS3 (red, Alarm) is off (Figure 2.3).
7. AC Fuse - The fuse is a 5 mm X 20 mm, 2 amp slow blow (Type T) and is inserted in the far slot in the drawer below the AC input as shown in Figure 2.4. There is a spare fuse in the near slot. If a fuse continues to open, the power supply is most likely defective.



**FIGURE 2.4 Fuse Location and Spare Fuse**

## 2.5 Menu Settings

### 2.5.1 Functions

This section describes operation of the front panel controls. There are three operator switches, the LCD display and alarm indicator LEDs. All functions for the equipment are controlled by these components. The functions are (see Figure 2.5):

#### **Power Up**

#### **Normal Display**

**Menu 1** Frequency in MHz

**Menu 2** Gain (+30 to +50)

**Menu 3** Set Unit to Remote Operation

**Menu 4** Select External 10 MHz Ref

**Menu 5** Set Remote mode (option Q)

**Menu 6** Set RS-485 address (option Q)

**Save Menu** When “R” is selected in any above menu or at the end of the menu options.

Alarm indications appear on the LEDs (see figure 2.3).

All program changes must start with the operation of the Menu/Execute switch and must also end with the operation of the Menu/Execute switch verified by the “Save Settings?” Menu. If this sequence is not followed, none of the changes will take effect. If programming is initiated and no operator action takes place for approximately 30 seconds (before the final press of the Menu/Execute switch) the display will revert to its previous status and you will need to start over.

## 2.5.2 Power On Settings

**NOTE: THE LAST STATUS OF A UNIT IS RETAINED EVEN WHEN POWER IS REMOVED. WHEN POWER IS RESTORED, THE UNIT WILL RETURN TO ITS PREVIOUS SETTINGS.**

When power is first applied, the LCD display goes through three steps.

1. The LCD goes black to show all segments are functioning.
2. The software version will be displayed.



REV 1.00

3. The present frequency and gain of the downconverter is shown.

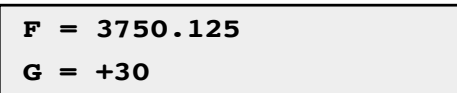

F = 3750.125  
G = +30

The unit is now operational and ready for any changes the operator may desire.

## 2.5.3 Control Switches

1. Menu/Execute - Any change to the programming of the unit must be initiated by pressing the Menu/Execute switch and completed by pressing the Menu/Execute switch.
2. Horizontal Switch - This switch is mounted so its movement is horizontal and moves the cursor left or right.
3. Vertical Switch - This switch is mounted so its movement is vertical and has two functions:
  - a. During frequency, gain changes, the vertical movement will raise or lower the number in the direction of the arrows.
  - b. For other functions such Mute on/off, the vertical switch will alternately turn the function on or off regardless of the direction operated.

## 2.5.4 Frequency Changes

At any time during the modification process, if you have made a mistake and do not wish to save the changes you have made, **do not press the Menu/Execute switch**; simply do nothing for approximately 30 seconds, and the system will return to the normal operating mode or scroll to “**R**” and push the Menu/Execute switch and select “**NO**” in the “**SAVE SETTINGS?**” window.

To change the FREQUENCY:

Operate the Menu/Execute switch until you get to the menu item you want to change see Figure 2.5 for the sequence of menu options. The following display is for changing the downconverter frequency:

```
F = 3750.125      R
```

Pressing the Up/Down switch down will toggle the display to:

```
F = 3850.125      R
```

By using the horizontal rocker switch the cursor can be moved left or right .

```
F = 3850.125      R
```

**NOTE: CHANGES DO NOT TAKE PLACE ON FREQUENCY UNTIL YOU GO TO THE SAVE MENU AND INDICATE YOU WANT TO SAVE THE CHANGES.**

When the display indicates the value desired you can push the Menu/Execute switch to get to the next item:

```
G = +30          R
```

OR you can scroll to “R”, push the Menu/Execute switch to get to:

```
SAVE SETTINGS?   Y N
```

Selecting **Y** will save the new settings. Selecting **N** will revert to the previous settings.

Pushing the Menu/Execute switch then takes you to this:

```
F = 3850.125
G = +30
```

Figure 2.5 gives the menu items and how to make changes.

## 2.5.5 Gain Changes

When you get to this menu note that the gain changes will be made as you make them but if you do not wish to save the changes you have made, scroll to “**R**” and push the Menu/Execute switch and select “**NO**” in the “**SAVE SETTINGS?**” window or **do not press the Menu/Execute switch**; simply do nothing for approximately 30 seconds, and the system will return to the normal operating mode.

To change the GAIN:

Push the Menu/Execute switch to get to the gain setting (See Figure 2.5 for the sequence of menu options):

<b>G = +<u>3</u>0</b>	<b>R</b>
-----------------------	----------

Pressing the Up/Down switch will change the gain in 1 or 10 dB steps depending on the cursor location:

<b>G = +<u>4</u>0</b>	<b>R</b>
-----------------------	----------

By using the horizontal rocker switch the cursor can be moved left or right. Pressing the Up/Down switch will toggle the display digit selected until you have the desired gain:

<b>G = +4<u>0</u></b>	<b>R</b>
-----------------------	----------

**NOTE: THE GAIN WILL BE CHANGED AS YOU ADJUST THE NUMBERS. HOWEVER, THE VALUE WILL NOT BE STORED UNTIL YOU INDICATE YES IN THE SAVE SETTINGS WINDOW.**

When the display indicates the value desired you can push the Menu/Execute switch to get to the next item:

<b>REMOTE</b>	<b><u>O</u>FF</b>	<b>R</b>
---------------	-------------------	----------

OR you can scroll to “**R**” and push the Menu/Execute switch to get to:

<b>SAVE SETTINGS?</b>	<b><u>Y</u> N</b>
-----------------------	-------------------

Selecting **Y** will save the new settings. Selecting **N** will revert to the previous settings. Pushing the Menu/Execute switch then takes you to this:

<b>F = 3850.125</b>
<b>G = +40</b>

Figure 2.5 gives the menu items and how to make changes.

## 2.5.5 Alarm Indications

An alarm condition will occur if any local oscillator phase lock loop (PLL) comes out of lock. The Mute LED will light if you select Mute and the Remote LED will light when you select the Remote mode.

ON POWER UP		
<b>Power Up</b>	REV 1.00	
NORMAL DISPLAY		
<b>Normal Display</b>	F = 3750.125 G = +30	
PUSHING MENU/EXECUTE SEQUENCE		
<b>Menu 1</b> Frequency	F = 3 <u>7</u> 50.125 R	
<b>Menu 2</b> Gain (+30 to +50)	G = +3 <u>0</u> R	
<b>Menu 3</b> Set Unit to Remote Operation	REMOTE <u>O</u> FF R	SCROLL ⇄ SCROLL ⇄ PUSH BUTTON
<b>Menu 4</b> Select External 10 MHz Reference	EXT REF <u>O</u> FF R	SCROLL ⇄ SCROLL ⇄ PUSH BUTTON
<b>Menu 5</b> Set Remote Mode (option Q)	RS 485 <u>O</u> FF R	SCROLL ⇄ SCROLL ⇄ PUSH BUTTON
<b>Menu 6</b> Set RS-485 Address (option Q)	ADDRESS = <u>0</u> 0 R	SCROLL ⇄ SCROLL ⇄ PUSH BUTTON
<b>Save?</b> When "R" is selected or at the end of the menu	SAVE SETTINGS? <u>Y</u> N	SCROLL ⇄ PUSH BUTTON

**FIGURE 2.5 Menu Display and Sequence**



6170 Shiloh Road  
Alpharetta, Georgia 30005

(770) 886-8005  
FAX (770) 886-7964  
Toll Free 888-900-5588

WEB [www.crosstechnologies.com](http://www.crosstechnologies.com)  
E-MAIL [info@crosstechnologies.com](mailto:info@crosstechnologies.com)